

Quasar 1200

1200 kN Advanced Universal Testing Machine

TQ01.11

The 1200 kN Quasar is the product of state of the art design, built to the highest quality levels and has many advanced technical features.

Programming tests and monitoring results can be controlled through our powerful and Intelligent Labtest software, which allows complete and accurate data management in accordance with European, North American and International Standards.

This instrument is suitable for use both in production lines where the operator has to be fast and efficient and can accurately control the test with the optional remote control unit and also laboratory environments where the advanced software lets users analyse the test data. Labtest allows full control of processing, filing, managing, and transmitting data to the company network, database, and performs many other functions.

This Quasar frame has a flexible and modular construction. It can be equipped with various grips and fixtures, as well as extensometers, additional load cells, temperature chambers and many more accessories, for a wide range of applications (tensile, compression, flexure, etc.).

In addition, this user-friendly instrument can be fitted with additional load cells with lower capacities, providing the highest resolution and accuracy for micro-loads.

- ❑ Two-column rigid system with 1200 kN maximum capacity
- ❑ Suitable for metals, composites and other materials
- ❑ Stylish design and advanced features
- ❑ Ergonomic for intensive use; 4.0 instrument
- ❑ Flexible and modular design for easy future development
- ❑ Key technical advantages include extremely high resolution of load and stroke readings, as well as minimum test speed of 0.0005 mm/min, for the high performance and most accurate results
- ❑ Manufactured by an ISO 9001 certified company
- ❑ Excellent price-to-quality ratio



Ethernet connection



Universal testing machine Quasar 1200
with Hydraulic parallel closing grip and
"Micron" extensometer

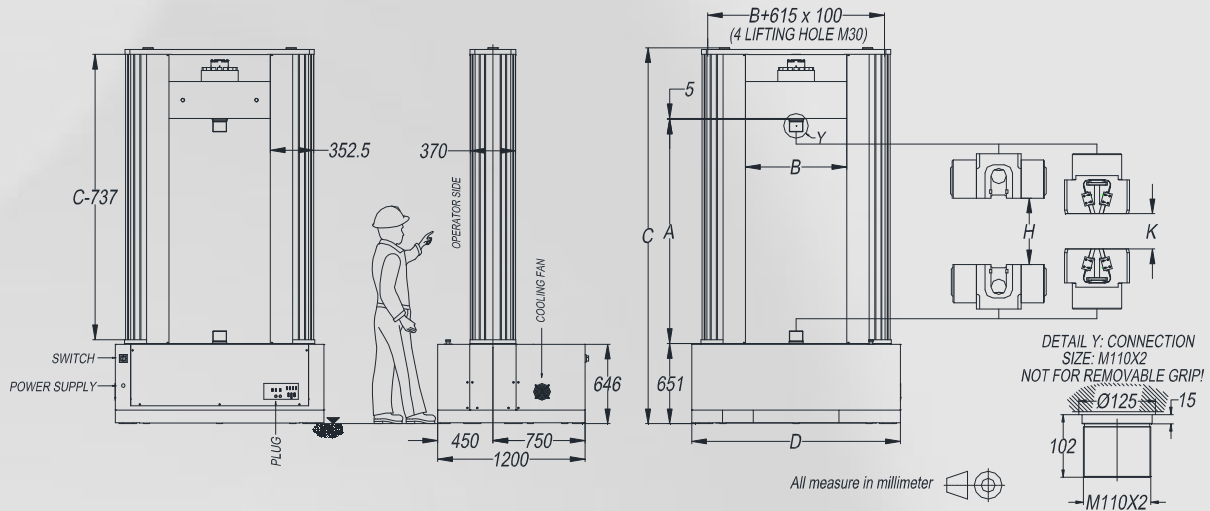

TECHNICAL SPECIFICATIONS:

ITEM	TQ01.11 ⁽¹⁰⁾
Capacity of frame and max admissible load	1,200 kN (269,771 lbf)
Load cell nominal size (tensile & compression)	1,000 kN ⁽¹⁾
Max accidental overload ⁽¹¹⁾ / breaking load	1,500 kN / 3,000 kN ⁽¹⁾
Standards met or exceeded	ISO 7500-1, ASTM E4, EN 10002-2, JIS B7721, GB/T 16825.1, DIN 51221, BS 1610 and other equivalent
Load cell reading resolution	Over 3 million division (24 bit A/D converter)
Stroke resolution	0.0015 µm/impuls
Speed at maximum load (in test)	0.0005 ÷ 200 mm/min.
Idle speed	200 mm/min.
Accuracy of positioning repeatability	0.002 mm (2 µm)
Frame Stiffness	550 kN
Distance between connection (Dimension A)	695 ÷ 1,825 mm (27.36 ÷ 71.85 in.)
Distance between standard hydraulic parallel closing grip (Dim. H)	1,100 mm (43.31 in.)
Distance between standard pneumatic wedge grip (Dimension K)	850 mm (33.46 in.)
Daylight between columns (Dimension B)	825 mm (32.48 in.)
Testing area depth	Unlimited ⁽⁴⁾
Power Supply	400÷440V 50/60Hz three phases (other on request) ⁽⁵⁾
Power Rating	7,000 W
Machine weight (without accessories)	3,700 Kg (8,160 lb)
Finishing	Silver RAL 9006 / Black RAL 9011
Ambient temperature	From +5 to +40 °C
Air humidity (without condensing)	Max 80%
Internal data sampling rate	1,000 Hz
PC data transmission rate	500 Hz
PC interface	Ethercat (A dedicated Ethernet port on PC is required)
Dimension: Height (Dimension C) ± 5 mm	3,057 mm (120.35 in.)
Dimension: Width (Dimension D)	1,700 mm (66.93 in.)
Dimension: Depth ⁽⁶⁾	1,200 mm (47.24 in.)
Dimension of international shipping box – approx ⁽⁷⁾	3,400x2,000 H1,800 mm
Noise level	< 72 db
Suggested light local level	300 lux

⁽¹⁾ Data of standard 1000 kN load cell. See below for other available auxiliary load cell
⁽²⁾ Crosshead deflection and elongation of lead screw drive approx including load cell, hydraulic grip and and drive approx
⁽³⁾ Average on 1 second or 0,01 mm of stroke (the longer in time) without or constant load
⁽⁴⁾ Some type of extensometers or other devices may reduce this value
⁽⁵⁾ Some optional devices need a compressed air line (5 bar) or different power supply
⁽⁶⁾ Frame dimension. Electrical connectors on the rear of the machine. See drawing
⁽⁷⁾ Machine is packed and travel in lying position

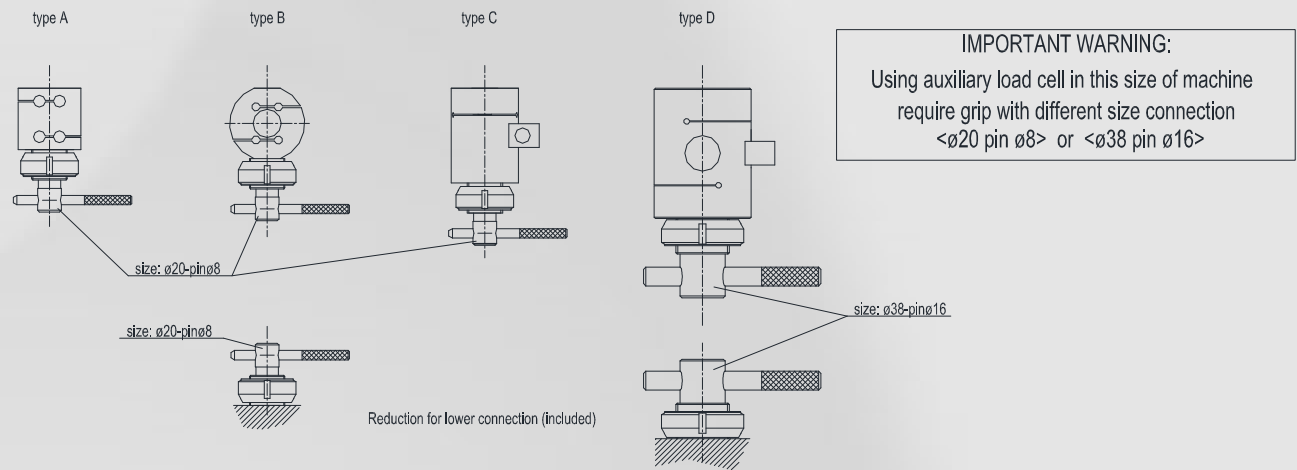

AVAILABLE MAIN / AUXILIARY LOAD CELL: ⁽⁸⁾

ITEM	TQ03.04.01	TQ03.04.01.0A	TQ03.04.01.0B	TQ03.04.02	TQ03.04.03	TQ03.04.03.0A	TQ03.04.04	TQ03.04.05	TQ03.04.06	TQ03.04.07	TQ03.04.08	On request	On request
Nominal size	10 N	20 N	50 N	100 N	250 N	500 N	1 kN	3kN ⁽¹²⁾	5 kN	10 kN	25 kN	50 kN	100 kN
Max accidental overload ⁽¹¹⁾ / breaking load	150% of nominal size / 300% of nominal size												
Type (see drawing)	A			B				C			D		
Kit for use as auxiliary cell (sold separately) ⁽¹³⁾	On request (depending on the configuration)												

⁽⁸⁾ The main load cell is always a **1000 kN** size. No limit in number of auxiliary load cell to be used under the main one.

All load cell can work in compression and tensile. If certification is required, every load cell (included main one) needs a different one.

⁽¹⁰⁾ Standard **1000kN** load cell is included in the item of the frame machine

⁽¹¹⁾ A new calibration of the load cell may be necessary if "max accidental overload" is exceeded.

⁽¹²⁾ Max load of TQ03.04.05 load cell is software limited to **2.5 kN**.

⁽¹³⁾ The kit include female and male connection, pin and locknut (as in draw). Every auxiliary load cell need **1** kit. Using auxiliary cell need grip with correct connection. The kit depending from grip permanently assembled on machine (wedge, shoulder, hydraulic...)

Galdabini Spa, Via Giovanni XXIII, 183 21010 Cardano al Campo (VA) Italy

T +39 0331 732700

F +39 0331 730650

info@galdabini.it

galdabini.it

