

Quasar 10

10 kN Advanced Universal Testing Machine

TQ01.03
TQ01.03.01
TQ01.03.02
TQ01.03.03
TQ01.03.04

The 10 kN Quasar is the product of state of the art design, built to the highest quality levels and has many advanced technical features.

Programming tests and monitoring results can be controlled through our powerful and Labtest software, which allows complete and accurate data management in accordance with European, North American and International Standards.

This instrument is suitable for use both in production lines where the operator has to be fast and efficient and can accurately control the test with the optional remote control unit and also laboratory environments where the advanced software lets users analyse the test data. Labtest allows full control of processing, filing, managing, and transmitting data to the company network, database, and performs many other functions.

This Quasar frame has a flexible and modular construction. It can be equipped with various grips and fixtures, as well as extensometers, additional load cells, temperature chambers and many more accessories, for a wide range of applications (tensile, compression, flexure, etc.).

In addition, this user-friendly instrument can be fitted with additional load cells with lower capacities, providing the highest resolution and accuracy for micro-loads.



Universal testing machine Quasar 10
with Micron extensometer

- Two-column rigid system with 10 kN maximum capacity
- Suitable for metals, plastics, composites and other materials
- Stylish design and advanced features
- Ergonomic and design; 4.0 instrument
- Flexible and modular design for easy future development
- Key technical advantages include extremely high resolution of load and stroke readings, as well as minimum test speed of 0.0005 mm/min, for the high performance and most accurate results
- Manufactured by ISO 9001 Certified Company
- Excellent price-to-quality ratio



Ethernet connection

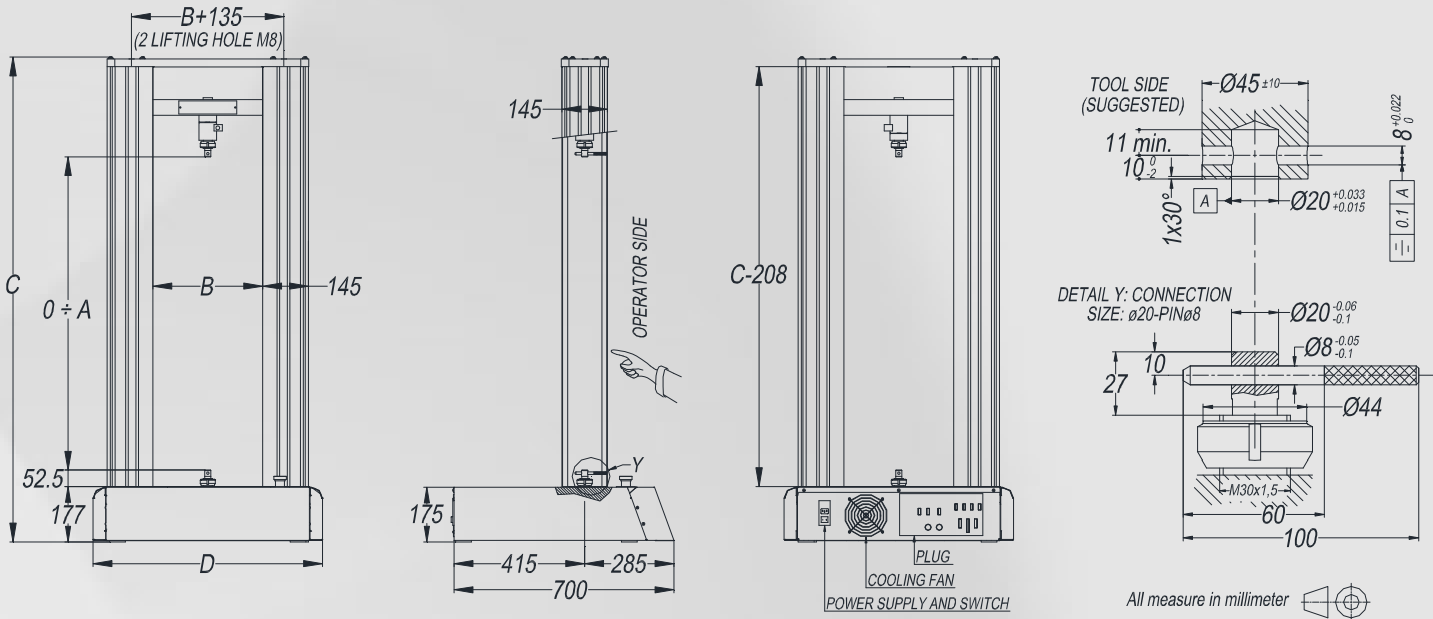

TECHNICAL SPECIFICATIONS

ITEM ⁽¹⁰⁾	TQ01.03	TQ01.03.01	TQ01.03.02	TQ01.03.03	TQ01.03.04
Capacity of frame and max allowed load	10,000 N (2,248 lbf)				
Load cell nominal size (tensile & compression)	10,000 N ⁽¹⁾				
Max accidental overload ⁽²⁾ / breaking load (with above load cell)	15,000 N / 30,000 N ⁽¹⁾				
Standards met or exceeded	ISO 7500-1, ASTM E4, EN 10002-2, JIS B7721, GB/T 16825.1, DIN 51221, BS 1610 and other equivalent				
Load cell reading resolution	Over 3 million division (24 bit A/D converter)				
Internal stroke resolution	0.043 mm (0.093 mm with optional item TQ02.01)				
Speed at maximum load (during test)	0.0005 ÷ 500 mm/min. (0.0005 ÷ 1,000 mm/min. with optional item TQ02.01)				
Idle speed	500 mm/min. (1,000 mm/min. with optional item TQ02.01)				
Accuracy of positioning repeatability	0.02 mm (20 µm)				
Accuracy of the set crosshead speed	0.5% of setting speed ⁽²⁾				
Total stroke (Dimension A) [mm / in.]	1,000 / 39.37	1,500 / 59.05	1,750 / 68.90	1,000 / 39.37	1,750 / 68.90
Daylight between columns (Dimension B) [mm / in.]	350 / 13.78			510 / 20.08	
Testing area depth	Unlimited ⁽³⁾				
Power Supply	To be chosen: 220V±10% 50/60Hz or 120V±10% 50/60Hz (other on request) ⁽⁴⁾				
Power Rating	700 W				
Machine weight (without accessories)	160 Kg (353 lb)	176 Kg (388 lb)	185 Kg (408 lb)	195 Kg (430 lb)	210 Kg (463 lb)
Finishing	Silver RAL 9006 / Black RAL 9011				
Room temperature	From +5 to +40 °C				
Air humidity (without condensing)	Max 80%				
Internal data sampling rate	1,000 Hz				
PC data transmission rate	500 Hz				
PC interface	Ethernet (A dedicated Ethernet port on PC is required)				
Dimension Height (Dimension C) ± 3 mm	1,548 / 61	2,098 / 82.6	2,348 / 92.5	1,548 / 61	2,348 / 92.5
Dimension Width (Dimension D) [mm / in.]	730 / 28.8	730 / 28.8	730 / 28.8	890 / 35	890 / 35
Dimension Depth ⁽⁵⁾	700 / 27.6				
Size when packed – approx ⁽⁶⁾ [mm]	900x900 H1,800	900x900 H2,400	900x2,650x H1,000	1150x900 H1,800	1150x2,650x H1,000
Noise level	< 72 db				
Suggested local light level	300 lux				

⁽¹⁾ Data of standard 10 KN load cell. See below for other available main/auxiliary load cell

⁽³⁾ Some type of extensometers or other devices may reduce this value

⁽⁴⁾ Some optional devices need a compressed air line (5 bar) or different power supply

⁽⁵⁾ Frame dimension. Electrical connectors on the rear of the machine. See drawing

⁽⁶⁾ TQ01.03.02 and TQ01.03.04 are packed and travel in lying position

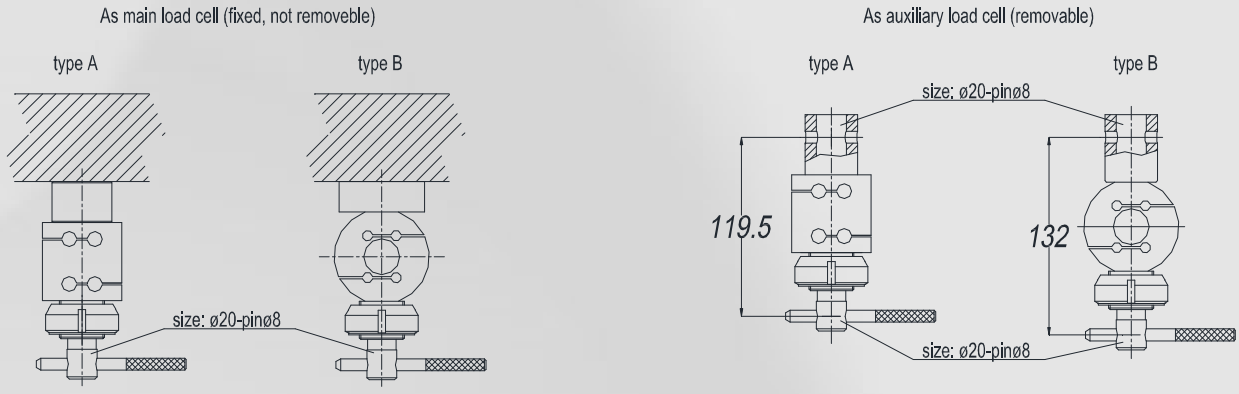

AVAILABLE MAIN / AUXILIARY LOAD CELL: ⁽⁸⁾

ITEM	TQ03.04.07	TQ03.04.01	TQ03.04.01.0A	TQ03.04.01.0B	TQ03.04.02	TQ03.04.03	TQ03.04.03.0A	TQ03.04.04	TQ03.04.05
	standard ⁽⁸⁾								
Nominal size	10 kN	10 N	20 N	50 N	100 N	250 N	500 N	1 kN	2.5 kN
Max accidental overload ⁽⁹⁾ / breaking load	150% of nominal size / 300% of nominal size								
Type (see drawing)	standard ⁽⁸⁾			A			B		
Kit for use as aux. cell (sold separately) ⁽¹³⁾	-		TQ03.05.01 (generic code, correct load cell must be specified)						

⁽⁷⁾ The main load cell must have a capacity greater than all auxiliary cell in use. No limit in number of load cell. All load cell can work in compression and tensile and comes with connection. If certification is required, every load cell needs a different one.

⁽⁸⁾ Standard 10 kN load cell must be ordered separately in any case (not included in the item of the frame machine)

⁽⁹⁾ A new calibration of the load cell may be necessary if "max accidental overload" is exceeded.

⁽¹⁰⁾ The kit include female and male connection, pin and locknut (as in draw). Every auxiliary load cell need 1 kit.

Galdabini Spa, Via Giovanni XXIII, 183 21010 Cardano al Campo (VA) Italy

T +39 0331 732700
 F +39 0331 730650
info@galdabini.it
galdabini.it

