



QUANTUM 5

5 kN Advanced Universal Testing Machine

The 5 kN Quantum is the product of state of the art design, built to the highest quality levels and has many advanced technical features.

Programming tests and monitoring results can be controlled through our powerful and Intelligent LabTest test software, which allows complete and accurate data management in accordance with European, North American and International Standards.

This instrument can be used both in production lines, where the operator has to be fast and efficient and can accurately control the test with the optional remote control unit, and also laboratory environments, where the advanced software lets users analyse the test data.

LabTest allows full control of processing, filing, managing, and transmitting data to the company network, database, and performs many other functions.

This Quantum frame has a flexible and modular construction. It can be equipped with various grips and fixtures, as well as extensometers, additional load cells, temperature chambers and many more accessories, for a wide range of applications (tensile, compression, flexure, etc.).

In addition, this user-friendly instrument can be fitted with additional load cells with lower capacities, providing the highest resolution and accuracy for micro-loads.



Universal testing machine Quantum 5 with Micron extensometer

Features:

- Two-column rigid system with 5 kN maximum capacity
- Suitable for metals, plastics, composites and other materials
- Stylish design and advanced features
- Ergonomic design; 4.0 instrument
- Flexible and modular design for easy future development
- Key technical advantages include extremely high resolution of load and stroke readings, as well as minimum test speed of 0.0005 mm/min, for the high performance and most accurate results
- Manufactured by ISO 9001 and ISO 14001 Certified Company
- Excellent price-to-quality ratio

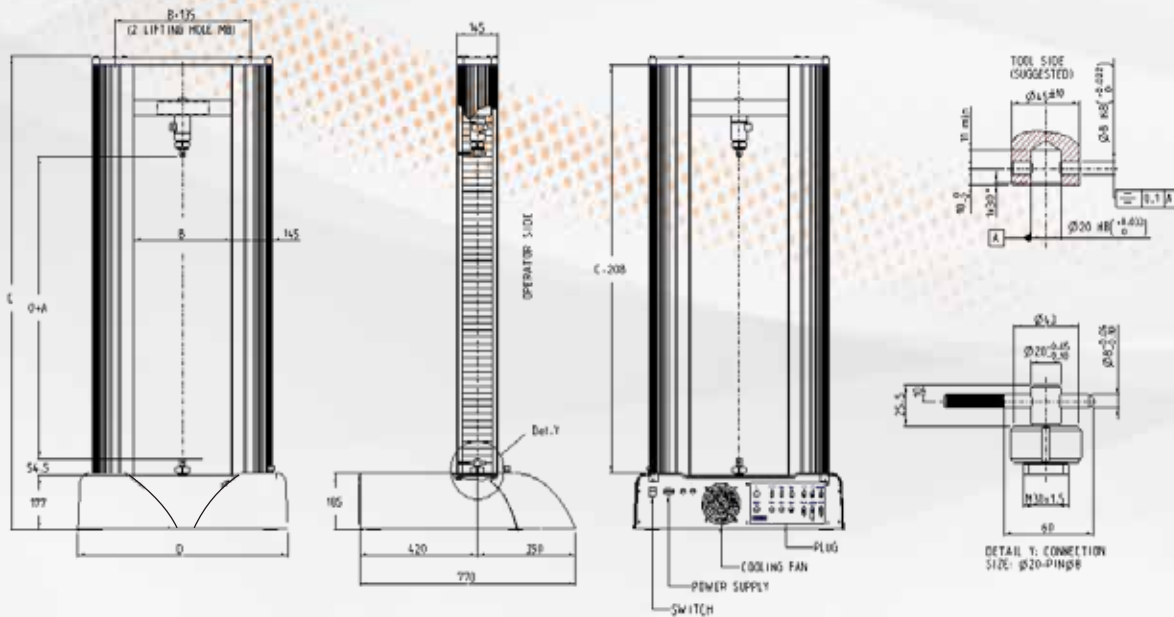

TECHNICAL SPECIFICATIONS

ITEM ⁽¹⁰⁾	TQ01.14	TQ01.14.01	TQ01.14.02	TQ01.14.03	TQ01.14.04	
Capacity of frame and max allowed load	5,000 N (1,124 lbf)					
Load cell nominal size (tensile & compression)	5,000 N (*)					
Max accidental overload ⁽⁹⁾ / breaking load (with above load cell)	7,500 N / 15,000 N (*)					
Standards met or exceeded	ISO 7500-1, ASTM E4, EN 10002-2, JIS B7721, GB/T 16825.1, DIN51221, BS 1610 and other equivalent					
Load cell reading resolution	Over 3 million division (24 bit A/D converter)					
Stroke resolution	0.0015 µm/Impuls					
Speed at maximum load (during test)	0.0005 ÷ 500 mm/min (0.0005 ÷ 1,000 mm/min with optional item TQ02.01)					
Idle speed	500 mm/min (1,000 mm/min with optional item TQ02.01)					
Accuracy of positioning repeatability	0.002 mm (2 µm)					
Accuracy of the set crosshead speed	0.5% of setting speed ⁽²⁾					
Total stroke (Dimension A) [mm/in.]	1,000 / 39.37	1,500 / 59.05	1,750 / 68.90	1,000 / 39.37	1,750 / 68.90	
Daylight between columns (Dimension B) [mm/in.]	350 / 13.78			510 / 20.80		
Testing area depth	Unlimited ⁽³⁾					
Power supply	To be chosen: 220V ± 10% 50/60 Hz or 120 V ± 10% 50/60 Hz - (others on request) ⁽⁴⁾					
Power rating	700 W					
Machine weight (without accessories)	152 kg (335 lb)	168 kg (370 lb)	177 kg (390 lb)	185 kg (408 lb)	200 kg (441 lb)	
Finishing	Silver RAL 9006 / Black RAL 9011					
Room temperature	From +5 to +40°C					
Air humidity (without condensing)	Max 80%					
Internal data sampling rate	1,000 Hz					
PC data transmission rate	500 Hz					
PC interface	Ethernet (A dedicated Ethernet port on PC is required)					
Dimensions: [mm/in.]	Height (Dimension C) ± 3 mm	1,548 / 61	2,098 / 82.6	2,348 / 92.5	1,548 / 61	2,348 / 92.5
	Width (Dimension D)	750 / 29.5	750 / 29.5	750 / 29.5	910 / 35.8	910 / 35.8
	Depth ⁽⁵⁾	770				
Size when packed - approx ⁽⁶⁾ [mm]	900x900 h 1,800	900x900 h 2,400	900x2,650 h 1,000	1150x900 h 1,800	1150x2,650 h 1,000	
Noise level	< 72 db					
Suggested local light level	300 lux					

- (1) Data of standard 5 KN load cell. See below for other available main/auxiliary load cell
 (2) Average on 1 second or 0.01 mm of stroke (longer in time) without or constant load
 (3) Some type of extensometers or other devices may reduce this value
 (4) Some optional devices need a compressed air line (5 bar) or different power supply
 (5) Frame dimension. Electrical connectors on the rear of the machine. See drawing
 (6) TQ01.14.02 and TQ01.14.04 are packed and travel in lying position

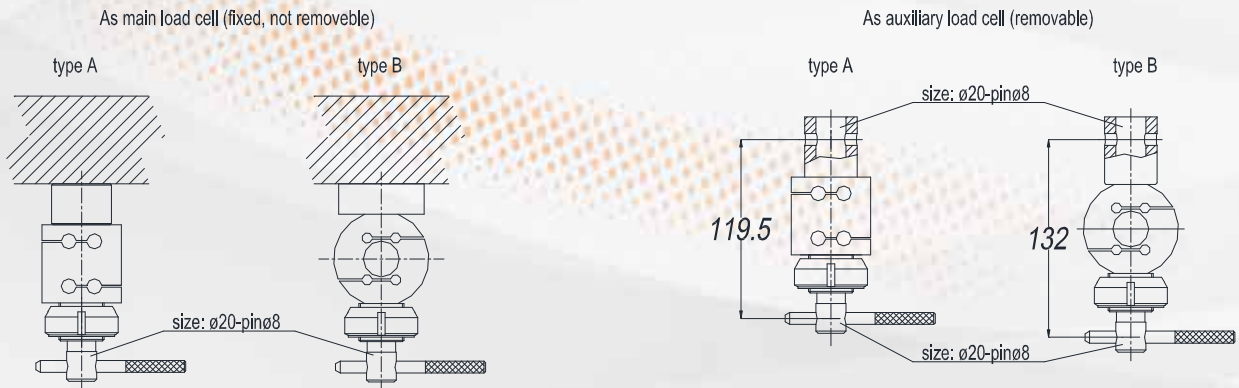

AVAILABLE MAIN / AUXILIARY LOAD CELL ⁽⁷⁾

ITEM	TQ03.04.06 Standard ⁽⁸⁾	TQ03.04.01	TQ03.04.01.0A	TQ03.04.01.0B	TQ03.04.02	TQ03.04.03	TQ03.04.03.0A	TQ03.04.04	TQ03.04.05	
Nominal size	5 kN	10 N	20 N	50 N	100 N	250 N	500 N	1 kN	2,5 kN	
Max accidental overload ⁽⁹⁾ /breaking load	150% of nominal size / 300% of nominal size									
Type (see drawing)	Standard ⁽⁸⁾	A					B			
Kit for use aux. cell (sold separately) ⁽¹⁰⁾	-	TQ03.05.01 (generic code, correct load cell must be specified)								

⁽⁷⁾ The main load cell must have a capacity greater than all auxiliary cell in use. No limit in number of load cell. All load cell can work in compression and tensile and comes with connection. If certification is required, every load cell needs a different one.

⁽⁸⁾ Standard 5 kN load cell must be ordered separately in any case (not included in the item of the frame machine)

⁽⁹⁾ A new calibration of the load cell may be necessary if "max accidental overload" is exceeded.

⁽¹⁰⁾ The kit include female and male connection, pin and locknut (as in draw). Every auxiliary load cell need 1 kit.



Galdabini Spa
Via Giovanni XXIII, 183
21010 Cardano al Campo (VA)
Italy

T +39 0331 732700
F +39 0331 730650
info@galdabini.it
galdabini.it