

Quasar 2.5

2.5 kN Advanced Universal Testing Machine

TQ01.01

Quasar 2.5 kN is the product of state of the art design, built to the highest quality levels and has many advanced technical features.

Programming tests and monitoring results can be controlled through our powerful and Labtest software, which allows complete and accurate data management in accordance with European, North American and International Standards.

This instrument is suitable to be used both in production lines where the operator has to be fast and efficient and can accurately control the test with the optional remote control unit and also laboratory environments where the advanced software lets users analyse the test data. Labtest allows full control of processing, filing, managing, and transmitting data to the company network, database, and performs many other functions.

This Quasar frame has a flexible and modular construction. It can be equipped with various grips and fixtures, as well as extensometers, additional load cells and many more accessories, for a wide range of applications (tensile, compression, flexure, etc.).

In addition, this user-friendly instrument can be fitted with additional load cells with lower capacities, providing the highest resolution and accuracy for micro-loads.



Universal testing machine Quasar 2.5
with pneumatic parallel grip

- ☐ Single-column rigid system with 2.5 kN maximum capacity
- ☐ Suitable for textile, plastic, composite and other materials
- ☐ Stylish design and advanced features
- ☐ Ergonomic design; 4.0 instrument
- ☐ Flexible and modular design for easy future development
- ☐ Key technical advantages include extremely high resolution of load and stroke readings, as well as minimum test speed of 0.0005 mm/min, for the highest performance and most accurate results
- ☐ Manufactured by ISO 9001 Certified Company
- ☐ Excellent price-to-quality ratio



Ethernet connection

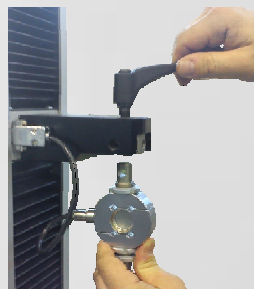

Easy load cell exchange
Auto recognized

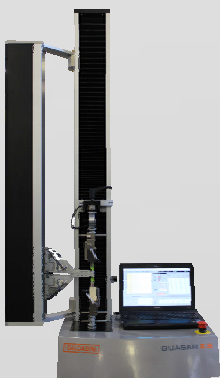

Extensometer available

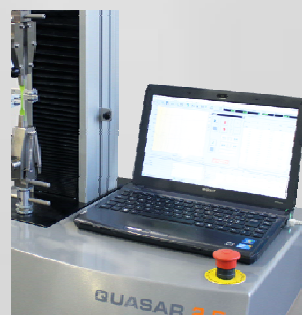

Ready for laptop

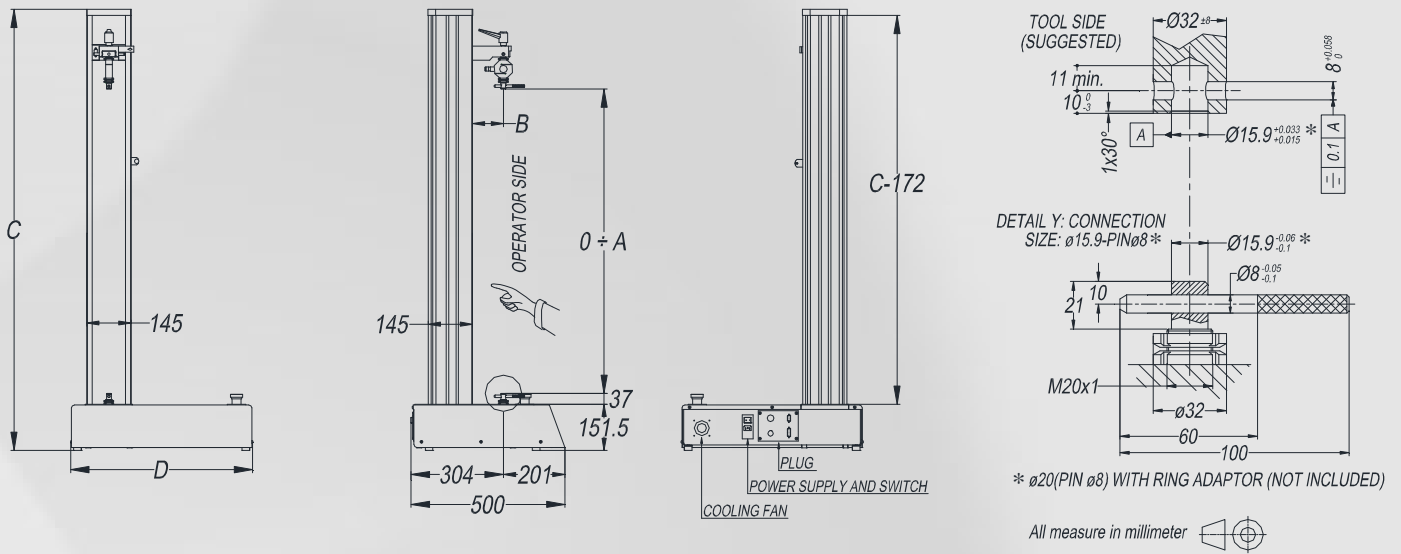

TECHNICAL SPECIFICATIONS

ITEM ⁽¹⁰⁾	TQ01.01
Capacity of frame and max allowed load	2,500 N (562 lbf)
Load cell nominal size (tensile & compression)	2,500 N ⁽¹⁾
Max accidental overload ⁽⁹⁾ / breaking load (with above load cell)	4,500 N / 9,000 N ⁽¹⁾
Standards met or exceeded	ISO 7500-1, ASTM E4, EN 10002-2, JIS B7721, GB/T 16825.1, DIN 51221, BS 1610 and other equivalent
Load cell reading resolution	Over 3 million division (24 bit A/D converter)
Internal stroke resolution	0.081 µm
Speed at maximum load (during test)	0.0005 ÷ 1,000 mm/min.
Idle speed	1,000 mm/min.
Accuracy of positioning repeatability	0.02 mm (20 µm)
Accuracy of the set crosshead speed	0.5% of setting speed ⁽²⁾
Total stroke (Dimension A)	1,000 mm (39.37 in.)
Distance from column (Dimension B)	101 mm (3.98 in.)
Testing area width	Unlimited ⁽³⁾
Power Supply	To be chosen: 220V±10% 50/60Hz or 120V±10% 50/60Hz (other on request) ⁽⁴⁾
Power Rating	250 W
Machine weight (without accessories)	66 Kg (145 lb)
Finishing	Silver RAL 9006 / Black RAL 9011
Room temperature	From +5 to +40 °C
Air humidity (without condensing)	Max 80%
Internal data sampling rate	1,000 Hz
PC data transmission rate	500 Hz
PC interface	Ethercat (A dedicated Ethernet port on PC is required)
Dimension: Height (Dimension C) ± 3 mm	1,452 mm (57.2 in.)
Dimension: Width (Dimension D)	595 mm (23.4 in.)
Dimension: Depth ⁽⁵⁾	500 mm (19.7 in.)
Size when packed – approx ⁽⁶⁾	700x800 H1,700 mm
Noise level	< 72 db
Suggested local light level	300 lux

⁽¹⁾ Data of standard load cell. See below for other available load cells

⁽²⁾ Some type of extensometers or other devices may reduce this value

⁽³⁾ Some optional devices need also a compressed air line (5 bar) or different power supply

⁽⁴⁾ Frame dimension. Electrical connectors on the rear of the machine. See drawing

⁽⁵⁾ Machine is packed and travels in working position (not lying)

⁽⁶⁾ Machine is packed and travels in working position (not lying)

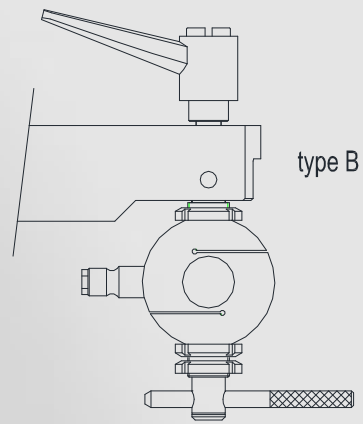
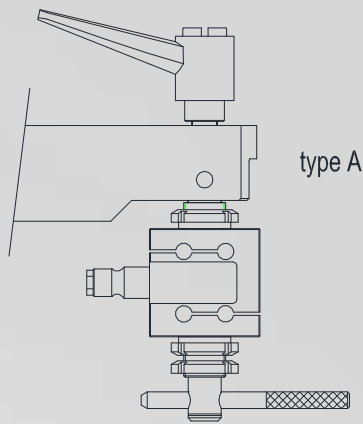

AVAILABLE LOAD CELL: ⁽⁷⁾ ⁽⁸⁾								
ITEM	TQ03.04.01	TQ03.04.01.0A	TQ03.04.01.0B	TQ03.04.02	TQ03.04.03	TQ03.04.03.0A	TQ03.04.04	TQ03.04.05 (standard)
Nominal size	10 N	20 N	50 N	100 N	250 N	500 N	1 kN	2.5 kN
Max accidental overload ⁽⁹⁾ / breaking load	150% of nominal size / 300% of nominal size							See above
Type (see drawing)	A				B			

⁽⁷⁾ No limit in number of load cell. All load cell can work in compression and tensile and comes with connection
If certification is required, every load cell needs a different one

⁽⁸⁾ Load cell must be ordered separately in any case (not included in the item of the machine frame)

⁽⁹⁾ A new calibration of the load cell may be necessary if "max accidental overload" is exceeded

Galdabini Spa, Via Giovanni XXIII, 183 21010 Cardano al Campo (VA) Italy

T +39 0331 732700

F +39 0331 730650

info@galdabini.it

galdabini.it

