

# NEMESIS 6100

Rockwell Hardness Tester

FULLY **AUTOMATIC**



# NEMESIS 6100

## Rockwell testing as the highest standard...

NEMESIS 6100 represents the latest top development of high speed production Rockwell hardness testing, standing for modern design, latest technology, multi-purpose hardness testing and precision mechatronic components. The rigid linear force actuator moves the test head in the required position, providing hardness testing results at the highest standard. Aircraft engine parts, automobile parts, production lines, general quality assurance and laboratory use are all covered by the NEMESIS 6100.



### HARDNESS SCALES



**ROCKWELL** 3kgf – 150kgf



**BRINELL** 1kgf – 250kgf

### ROCKWELL & BRINELL FORCE RANGE:

3kgf	<b>NEMESIS 6100RS</b>	150kgf	250kgf
------	-----------------------	--------	--------

## HIGHLIGHTS

- 1 Load cell, closed loop, linear force actuator
- 2 Fixed workpiece position
- 3 Descending test head
- 4 Extended indenter base with high force clamping attachment and indenter protection
- 5 Embedded high quality electronic system with 6,5" color display
- 6 Menu structured operating i-Touch software
- 7 Brinell scales (optional)
- 8 Large test piece accommodation : 345mm (H) x 220mm (D)
- 9 Top-class replaceable body parts, shock proof ABS covers

# CREATIVE INNOVATION

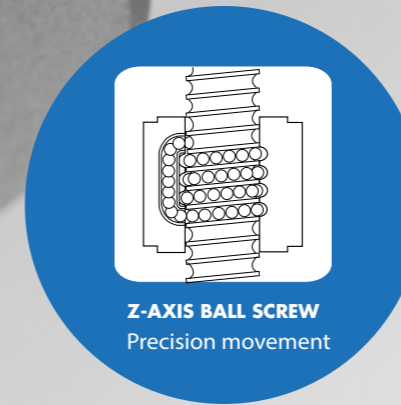

Vertical force actuator with position reading system

**STANDARD**  
Force adjustable workpiece clamp

Stage and anvil docking station

3-Axis joystick with fine adjustment

## Observe, Think, Try, Change...

Unparalleled in this class of Rockwell hardness testing machines is the electronic Load cell, force feedback, closed loop system, fully automatic, servo motor driven. Absolute maintenance free, automatic setting of test forces. Error free operation, due to an automatic test cycle, applying the main load and correct pre-set dwell time

## “Reliability is the pre-condition for trust...”

The I-Touch™ software provides clever multi-function keys for testing, set-up, storing and uploading of test programs, statistic control and more, making tester operation as easy as it can be. Data export, single or batch readings, with a single press on a button, or just fully automatic after measurement can be stored on a USB stick or transfer by cable to a PC to be imported or evaluated in EXCEL.

Further advanced features include extended statistics, shape correction for convex, concave or ball shaped specimens, hardness conversion to Rockwell, Brinell or Tensile strength according to ASTM E140 and ISO 18625 with different material tables.

There is a table top panel with an adjustable viewing angle or an integrated version that is imbedded in the testers frame. In all cases the panel is mounted in a solid robust aluminum frame.



# STARTING WITH I-TOUCH

## INNOVATIVE SOFTWARE FUNCTIONS

### 1 OUT OF SET LIMITS



### 2 DWELL TIME SETTINGS



### 3 MEASUREMENT OVERVIEW

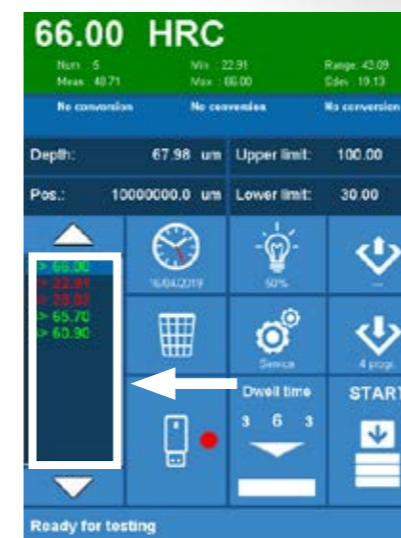

### 4 EXPORT FUNCTIONS



# VARIOUS POSSIBILITIES

The NEMESIS 6100 is a rock-solid Rockwell standardizing hardness tester. With a throat depth of 220 mm and a maximum working height of 345 mm, it provides a wide workspace for every type of user. Its solid body work can withstand the hardest environments. In short: NEMESIS 6100 is suitable for every industry.



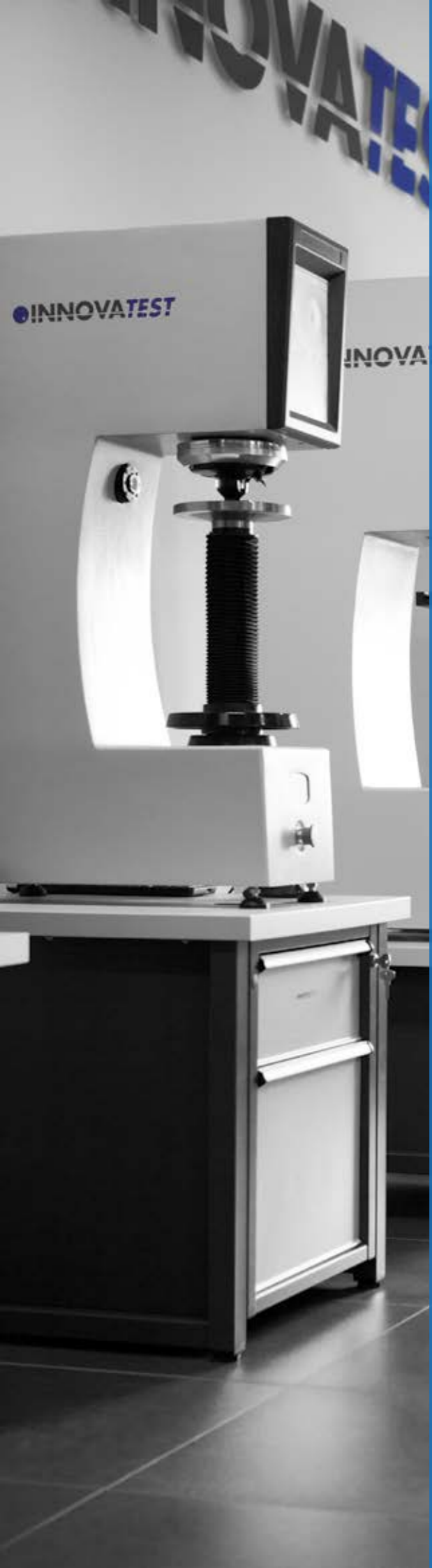

# SUPPORT YOUR BEST TESTING RESULTS

With our rigid designed Bench stands

- Rock solid bench stands
- 100% retractable drawer, bearing guidance, max 100kg load. Rubber anti slip bottom
- Lockable cabinet, 300mm high
- Adjustable feet, (+/- 50mm height adjustable to reach ergonomic working position)
- Made of corrosion resistant zinc plated steel with RAL powder coating
- Carrying capacity of 400kg
- Top surface made of 50mm Plywood with 1.5mm chemical resistant plastic plating, edges made of shock resistant 3mm ABS side liner
- Industrial quality, for workshop or laboratory

Designed for hardness testing instruments, painted in INNOVATEST® RAL colors matching our testers.



UN-STAND/960 71 x 75 x 80 cm



UN-STAND/965 150 x 75 x 80 cm

# ACCESSOIRES NEMESIS 6100

Schematic overview of the configuration options, standard and optional accessories

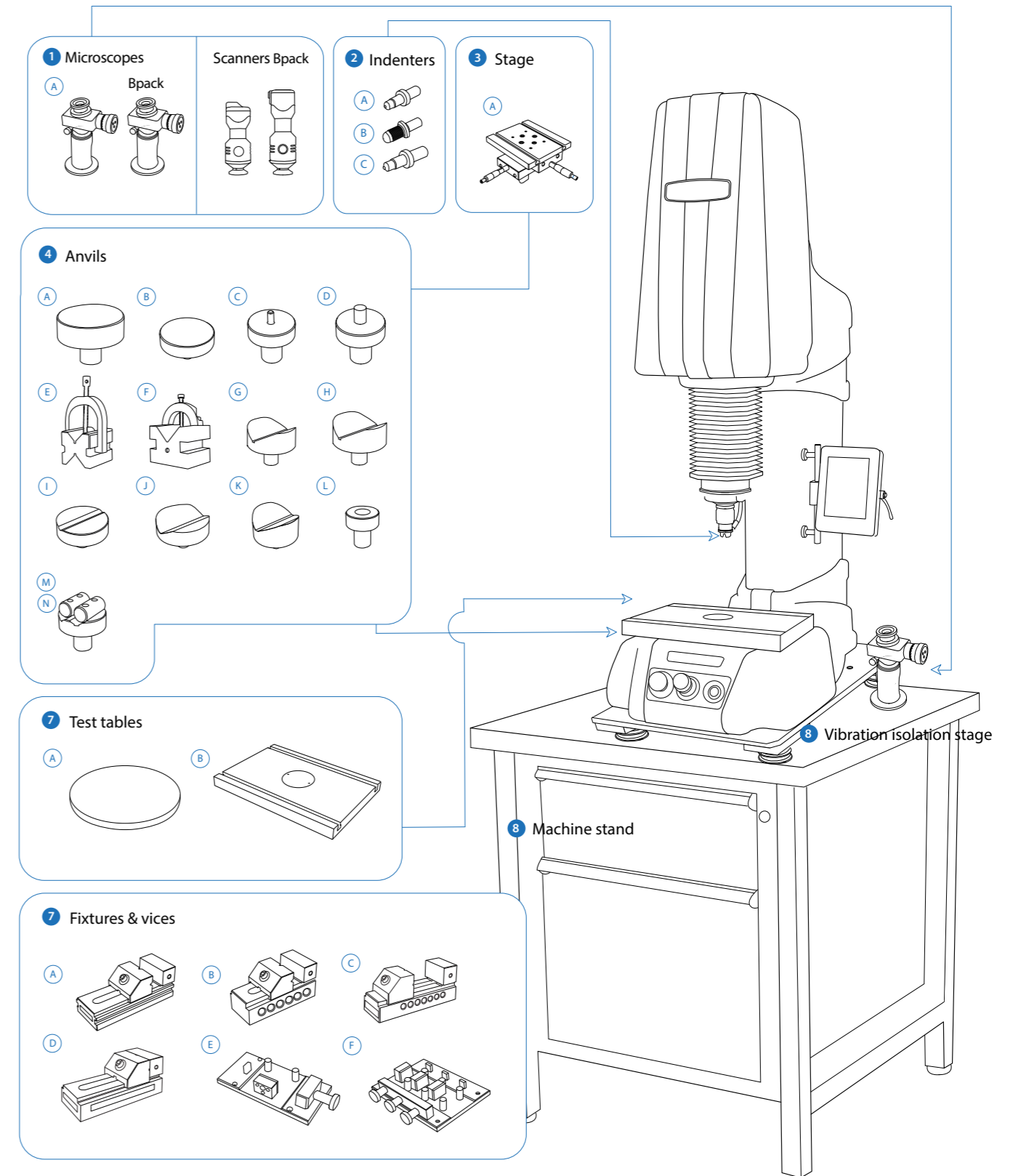

Not all accessories are displayed on this page. Full details can be found on the Order details page.

# ORDER DETAILS

## NEMESIS 6100



Digital, Twin Scale Load Cell Closed Loop, Rockwell hardness tester 3kgf - 150kgf, i-Touch system	NEMESIS 6100RS
Plug & Play prepared, calibration, sea & airworthy packing in "non coniferous wood" material	P&PSEAPACK80

## ACCESSORIES

1	Microscope	A	Analogue Brinell indent measuring microscope 20x Only in combination with UN-BPACK01	ASS3001-MICRO/01
2	Indenters	A	Rockwell C Diamond Indenter, ISO & ASTM certified	IN/6005
		B	Brinell Indenter 1mm. Includes 1 carbide ball. Ø6.35mm. ISO & ASTM certified	IN/7000
			Brinell Indenter 2.5mm. Includes 1 carbide ball. Ø6.35mm. ISO & ASTM certified	IN/7005
			Brinell Indenter 5mm. Includes 1 carbide ball. Ø6.35mm. ISO & ASTM certified	IN/7010
			Brinell Indenter 10mm. Includes 1 carbide ball. Ø6.35mm. ISO & ASTM certified	IN/7015
			Rockwell Ball Indenter 1/16". Includes 1 carbide ball, ISO & ASTM certified	IN/7506
			Rockwell Ball Indenter 1/8". Includes 1 carbide ball, ISO & ASTM certified	IN/7606
			Rockwell Ball Indenter 1/4". Includes 1 carbide ball, ISO & ASTM certified	IN/7706
			Rockwell Ball Indenter 1/2". Includes 1 carbide ball, ISO & ASTM certified	IN/7806
3	X-Y Manual Stage	C	Macro Vickers Indenter Ø6.35mm, ASTM/ISO certified	IN/8010
		A	Manual X-Y stage with analogue metric micrometers, 180x160mm Displacement: 25x25mm, scale 0.01mm, max load 300kg	UN-TESTTABLE/030
			Lock flange	UN-XYZ BUSH50
			Mounting plate for lock flange	UN-XYZ30FP50-55
4	Anvils		Quick change anvil base (required for mounting testing tables, anvils)	AS5000-450
		A	Flat anvil 60mm	AS3000-19-04
		B	Flat anvil 80mm	UN-TESTTABLE/002
		C	Spot anvil 5mm	UN-ANVIL/010
		D	Spot anvil 10mm	UN-ANVIL/011
		E	V block with bracket 40x40x50mm (LxBxH)	UN-VBLOCK404050
		F	Steel, cross type, (X) V-block 60x120x100mm 8-90mm pair	UN-CROSSBLOCK01
		G	V-anvil ø40mm 6-60mm	UN-ANVIL/005
		H	V-anvil ø63mm 10-100mm	UN-ANVIL/006
		I	V-Anvil ø80mm 3.3-20mm	UN-ANVIL/040
		J	V-Anvil ø80mm 12-80mm	UN-ANVIL/045
		K	V-Anvil ø80mm 20-140mm	UN-ANVIL/050
		L	Anvil for round specimen dia. 6-25,4mm	UN-ANVIL/200
		M	Cylindrical V anvil 6-80mm	UN-CVANVIL680
N	Cylindrical V anvil 50-200mm	UN-CVANVIL50200		
	Test table 100x100mm, V groove 20mm wide, 10mm deep	UN-TESTTABLE/040		

	Clamping, locking & fixing adapters		Quick change anvil base (required for mounting testing tables, anvils)	AS5000-450
5	Test tables	A	Testing table flat ø200mm, screwfix	UN-TESTTABLE/010
			Testing table flat ø235mm, screwfix	UN-TESTTABLE/012
			Quick change anvil base (required for mounting testing tables, anvils)	AS5000-450
6	Fixtures & vices	B	Large flat surface testing table 350x250mm, thickness 30mm with 2 T-slots, for large components	UN-TESTTABLE/015
			Large flat surface testing table 450x350mm, thickness 35mm with 2 T-slots, for large components	UN-TESTTABLE/016
		A	Polished precision vice with lock down system, jaw width 25mm, opens 20mm	UN-VICE/210
		B	Polished precision vice with lock down system, jaw width 36mm, opens 42mm	UN-VICE/215
		C	Polished precision vice with lock down system, jaw width 48mm, opens 75mm	UN-VICE/220
		D	Polished precision vice with lock down system, jaw width 75mm, opens 100mm	UN-VICE/230
7	Machine stand	E	JOMINY Fixture, for 1 quench end test sample, quick release function	UN-JOMFIX1
		F	JOMINY Fixture, for 3 quench end test sample, quick release function	UN-JOMFIX3
			Cabinet test table with drawer for hardness testers 71x75x80cm	UN-STAND/960
8	Vibration isolation stage		Seaworthy packing box for 950/960	PACK/100
			Passive vibration isolation stage, broad spectrum	UN-AVS-300
	ISO / ASTM Verification		BRINELL direct and indirect verification/calibration & certification in compliance with ISO & ASTM, NADCAP. Includes direct force and indirect verification report (block readings), GR & R report, flat fee for selected common scales, per scale.	CALCEFRDW/1B
			ROCKWELL direct and indirect verification/calibration & certification in compliance with ISO & ASTM, NADCAP. Includes direct force and indirect verification report (block readings), GR & R report, flat fee for selected common scales, per scale.	CALCEFRDW/1R
	Cover		Machine cover 800x800x1450mm	UN-COVER7

## SOFTWARE

Connectivity Plus		Interface cable for PC	UN-CABLE/910
		Utility software; Import test results in MS applications like Excel	UN-SW/905
Upgrades		Upgrade Rockwell tester RS to RSB, Brinell scales, analogue microscope 40x	UN-BPACK01
		Upgrade Rockwell tester RS to RSB, Brinell scales, BIOS 1 system, IMPRESSIONS™ Lite	UN-BPACK02
		Upgrade Rockwell tester RS to RSB, Brinell scales, BIOS 2 system, IMPRESSIONS™ Lite	UN-BPACK03

# ACCESSORIES

## MICROSCOPES



## SCANNERS



## INDENTERS



## STAGE



## ANVILS



## TEST TABLES



## FIXTURES AND VICES

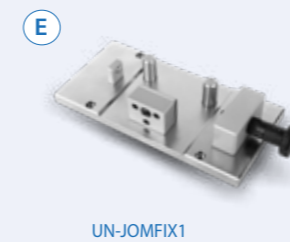

## MACHINE STAND



## VIBRATION ISOLATION STAGE





# SPECIFICATIONS

## HARDNESS SCALES

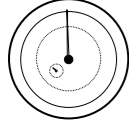
	<b>ROCKWELL</b> EN-ISO 6508, ASTM E18 JIS Z 2245	All Rockwell & Superficial Rockwell scales Pre Load 3kgf & 10kgf Main Load 15kgf, 30kgf, 45kgf, 60kgf, 100kgf & 150kgf
	<b>BRINELL</b> EN-ISO 6506, ASTM E10 JIS Z 2243	HBW1/1   HBW1/1.25   HBW1/2.5   HBW1/5   HBW1/10   HBW1/30 HBW2.5/6.25   HBW2.5/15.625   HBW2.5/31.25   HBW2.5/62.5   HBW2.5/7.8125 HBW5/25   HBW5/62.5   HBW5/125   HBW5/250 HBW10/100   HBW10/250
	<b>HVD (HVT)</b>	HV5   HV10   HV20   HV25   HV30   HV40   HV50   HV60   HV100   HV120   HV125   HV150
	<b>HBD (HBT)</b>	HB1/5   HB1/10   HB1/30 HB2.5/6.25   HB2.5/15.625   HB2.5/31.25   HB2.5/62.5 HB5/25   HB5/62.5   HB5/125   HB5/250 HB10/100   HB10/250
	<b>CARBON</b>	HR 2,5/7   HR 5/7   HR 5/15   HR 5/20   HR 5/40   HR 5/60   HR 5/100   HR 5/150   HR 10/20 HR 10/40   HR 10/60   HR 10/100   HR 10/150
	<b>CONVERSIONS</b>	Conversion to other hardness scales according to ASTM E140, ISO 18265, GB/T 1172

## TEST FORCE

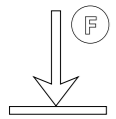
	<b>Force application</b>	Load cell, force feedback, closed loop system, fully automatic
	<b>Test forces</b>	Pre Load : 3kgf & 10kgf. Main Load : 15kgf, 30kgf, 45kgf, 60kgf, 100kgf & 150kgf
	<b>Force range per model</b>	6100RS 3kgf – 150kgf 6100RSB 1kgf – 250kgf
	<b>Test force tolerance</b>	<0.5%

## SYSTEM

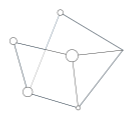
	<b>Electronic system</b>	Embedded high quality electronic system with 6,5" full color display, menu structured operating system
	<b>Screen(s)</b>	6,5" full color display
	<b>Display resolution</b>	Selectable 0.1 or 0.01HR, 0.5HB, others 0.1
	<b>Statistics</b>	Total test, max, min, average, range, standard deviation, All in real time after each test
	<b>Hardness conversion</b>	Rockwell, Rockwell Superficial, Vickers, Brinell, Knoop, Leeb & Tensile
	<b>Software</b>	I-Touch
<b>Connectivity</b>	2 x USB	

## GENERAL

	<b>Machine dimension</b>	1300 mm x 448 mm x 738 mm
	<b>Machine weight</b>	150kg
	<b>Power supply</b>	100VAC to 240VAC, 50/60Hz, single phase
	<b>Operating temperature</b>	10°C to 35°C, non-condensing
	<b>Power consumption</b>	100W
	<b>Humidity</b>	10% to 90%, non-condensing

# TECHNICAL DRAWINGS

All dimensions in these drawings are in mm, approximate. Working heights and or workpiece accommodation varies depending on the stages and stage accessories used.

Please contact our sales department for more details.

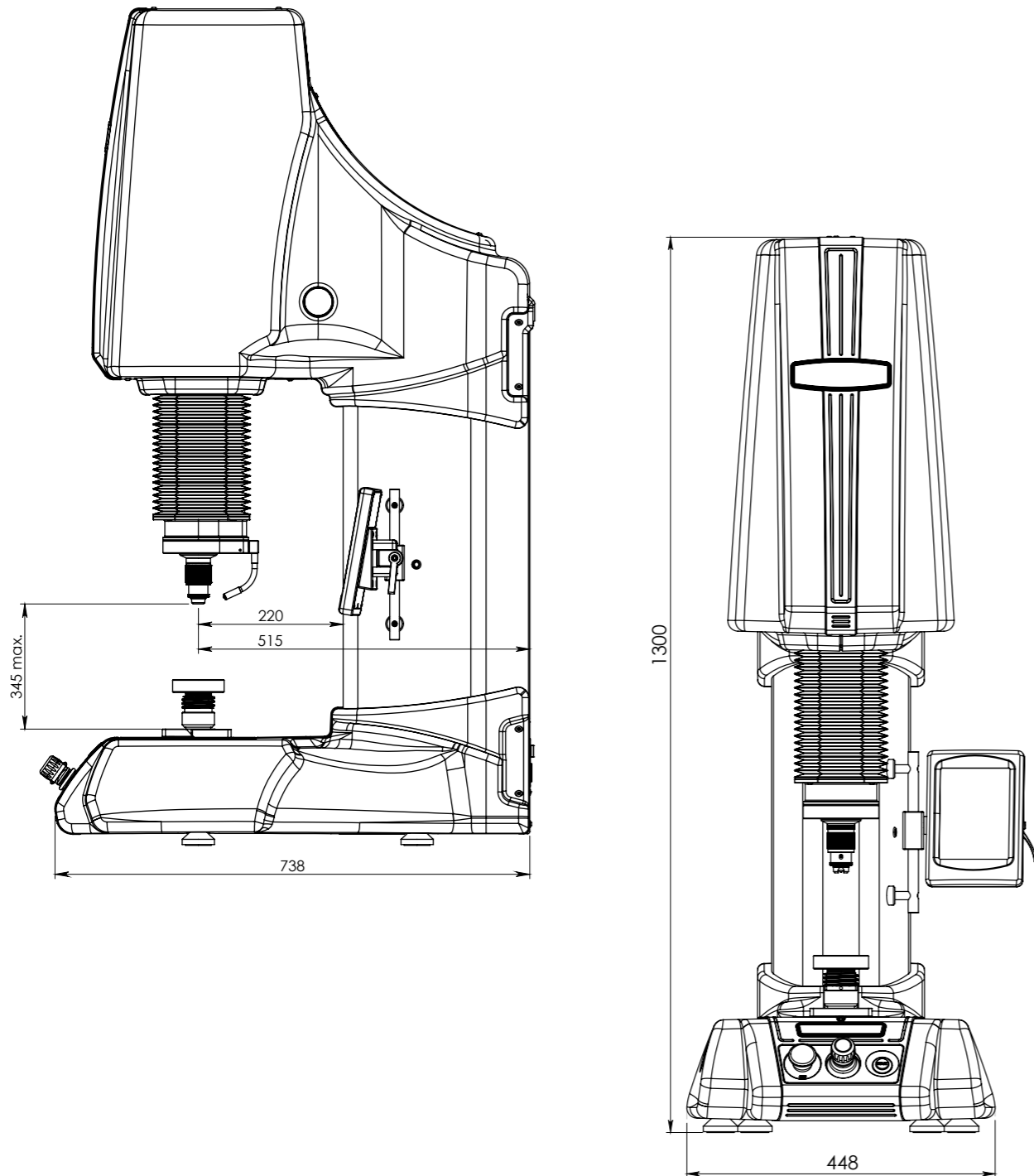

## OTHER MODELS IN THE ROCKWELL RANGE



### FENIX 200

Load Cell, closed loop, force feedback, test force application system Rockwell / Brinell hardness tester.  
See brochure B18F200/XX



### NEXUS 605

Load Cell, closed loop Rockwell/Super Rockwell/ Brinell hardness tester, with full color touch screen.  
See brochure B18N605/XX



### NEXUS 610

Load Cell, closed loop Rockwell/Super Rockwell/ Brinell hardness tester, with integrated PC, Windows 10, wifi etc. full color touch screen.  
See brochure B18N610/XX



### VERZUS 720

Load Cell, closed loop Rockwell/Super Rockwell/ Brinell hardness tester, with direct depth measuring system, integrated PC, Windows 10, wifi, full color touch screen.  
See brochure B18V710/XX



### NEMESIS 6200

Load Cell, Closed loop Fully automatic Rockwell/ Super Rockwell (Brinell) hardness tester with descending test head & fixed workpiece position, integrated PC, Windows 10, Wifi, full color 15" industrial capacitive touch screen.

Optional : CNC motorized X-Y stage, overview camera and advanced software (IMPRESSIONS) for automatic pattern testing and fixture recognition.  
See brochure B18N6200/XX

Changes in products and/or product specifications can emerge due to new technologies and continuous development.

We reserve the right to change or modify specifications of the products without prior notice. We recommend you to contact our sales office for up-to-date information.

Brochure B18N6100/06/EN

Distributor :

## **CORPORATE HEAD OFFICE**

### **INNOVATEST Europe BV**

**Manufacturing, Distribution & Service**

Borgharenweg 140  
6222 AA MAASTRICHT  
The Netherlands

Phone: +31 43 3520060

Fax: +31 43 3631168

[info@innovatest-europe.com](mailto:info@innovatest-europe.com)

[www.innovatest-europe.com](http://www.innovatest-europe.com)

#### **INNOVATEST Deutschland GmbH Sales & Service**

Phone: +49 245 670 59 500  
[info@innovatest-deutschland.com](mailto:info@innovatest-deutschland.com)  
[www.innovatest-deutschland.com](http://www.innovatest-deutschland.com)

#### **INNOVATEST France SARL Sales & Service**

Phone: +33 1848 88038  
[info@innovatest-france.com](mailto:info@innovatest-france.com)  
[www.innovatest-france.com](http://www.innovatest-france.com)

#### **INNOVATEST USA Company Sales & Service**

Phone: +1 267 317 4300  
[info@innovatest-usa.com](mailto:info@innovatest-usa.com)  
[www.innovatest-usa.com](http://www.innovatest-usa.com)

#### **INNOVATEST Japan Co., Ltd. Sales & Service**

Phone: +81 3 3527 3092  
[info@innovatest-japan.com](mailto:info@innovatest-japan.com)  
[www.innovatest-japan.com](http://www.innovatest-japan.com)

#### **INNOVATEST UK Ltd. Sales & Service**

Phone: +44 121 274 0105  
[info@innovatest-uk.com](mailto:info@innovatest-uk.com)  
[www.innovatest-uk.com](http://www.innovatest-uk.com)

#### **INNOVATEST Polska sp. z.o.o Sales & Service**

Phone: +48 697 099 826  
[info@innovatest-polska.pl](mailto:info@innovatest-polska.pl)  
[www.innovatest-polska.pl](http://www.innovatest-polska.pl)

#### **INNOVATEST Shanghai Co., Ltd. Sales & Service**

Phone: +86 21 60906200  
[info@innovatest-shanghai.com](mailto:info@innovatest-shanghai.com)  
[www.innovatest-shanghai.com](http://www.innovatest-shanghai.com)

#### **INNOVATEST South East Asia Sales & Service**

Phone: +65 6451 1123  
[info@innovatest-singapore.com](mailto:info@innovatest-singapore.com)  
[www.innovatest-singapore.com](http://www.innovatest-singapore.com)